



# The power to purify water and air with light

Philips purification lamps and drivers, protecting our world

**PHILIPS**

## Contents

3	Making the choice easy
4-9	Philips TUV low pressure mercury lamps and drivers
10-11	Philips TUV medium pressure mercury lamps
12	Philips TUV eXtreme power technology amalgam lamps
13	Philips ozone generating lamps
14	Philips TUV amalgam electronic drivers
15	Philips quartz sleeves
16-18	Circuit information
19	Wiring diagrams

# Making the choice easy

As the largest lamp manufacturer in the world, we bring you the very best in product innovation, reliability and quality. Using the knowledge of lighting technology that we have built up for more than 100 years, we offer a comprehensive portfolio of ultraviolet (UV) lamp and driver systems for a wide range of applications. From water and air purification to insect traps, colored lamps, aquariums, UV curing, blacklight blue and reprography.

We offer you a comprehensive choice from low pressure mercury lamps, quartz medium pressure lamps to high output amalgam lamps, ideal for use across a range of applications where purification is required. Complimentary to this lamp range, Philips offers a wide variety of drivers and sleeves.

We invented and pioneered the use of technology to reduce the mercury level of our lamps. As a result, we are very proud to have by far the lowest mercury level in ultraviolet (UV) lamps in the industry.

## **System performance and reliability**

When you choose Philips as a partner, we take complete responsibility for system performance and reliability. You deal with one supplier for the total system of lamp, driver and sleeve. This helps to avoid problems on any lamp compatibility failures and makes life easier for you.



# Philips TUV low pressure mercury lamps and drivers

Philips tubular ultraviolet (TUV) purification lamps help protect our world by de-activating bacteria, viruses and other primitive organisms safely and economically. Also effective when organisms have become immune to other purifying methods, Philips TUV lamps are ideal for use across a range of applications with the ability to purify air, water and surfaces.

From hospitals to laboratories. From food processing industries such as dairies, breweries and bakeries to cold storage rooms and air conditioning systems, Philips TUV lamps are the safe solution, making our surroundings cleaner, safer and more hygienic.

The technology behind Philips TUV lamps provides purification without the addition of chemicals. That makes it an ideal solution for residential and industrial water purification. You will also find that our lamps are used to make our swimming pools, ponds and aquariums cleaner.

Please contact us for tailor made solutions. Lamp life in hours and UVC output in Watts were measured with lamps operated under laboratory conditions. For reference purposes only. Actual life and output depends on operating conditions.

Bf-Bf = Base face - Base face

Bf-Te = Base face - Tube end



**Note:** Radiation from UVC lamps is harmful to eyes and skin.

Equipment using these lamps must screen completely from direct view.

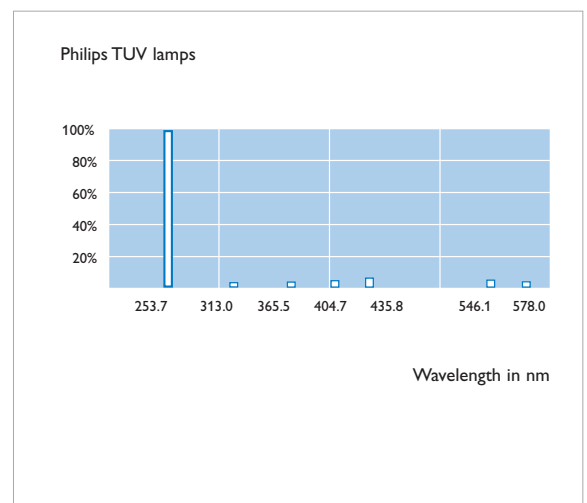
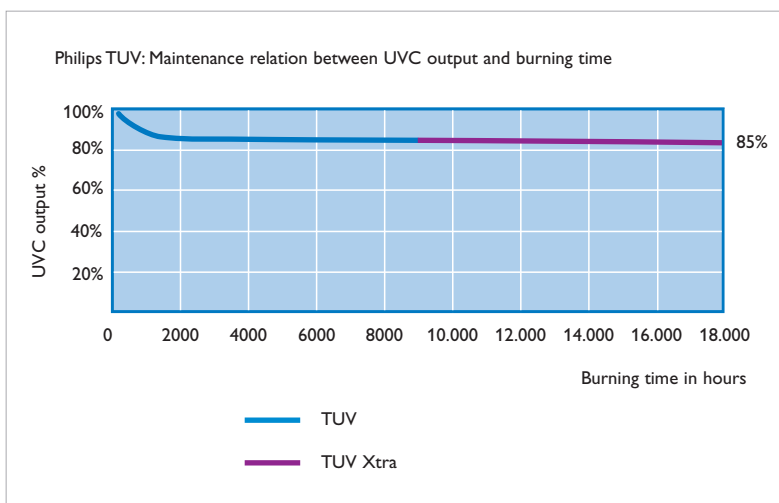

# Philips TUV low pressure straight tube lamps

Philips is the largest manufacturer of standard low pressure mercury lamps. These Philips TUV lamps consist of a tubular glass envelope emitting short-wave ultraviolet (UV) radiation with a peak at 254 nm (UVC) for germicidal action. The Philips in-house made glass filters out the 185 nm ozone forming line thus preventing the creation of ozone. High Output (HO) versions are available limiting required space and the footprint of your systems. Low pressure mercury lamps are very efficient, up to 40%. A protective coating on the inside limits the depreciation of the useful UVC output. This allows application manufacturers to design their systems to the highest efficiency. Philips invented and pioneered the use of technology to reduce the mercury level of the lamps. As a result this has been brought down to by far the lowest mercury level in UV lamps in the industry.

## Main applications:

- Residential drinking water units
- Stand alone air purifiers
- Wall-mounted air purification units

Features	Benefits
Coating on the inside	The UVC output over lifetime remains constant, allowing optimal design of the water/air treatment unit.
Lowest mercury level	More environmentally friendly

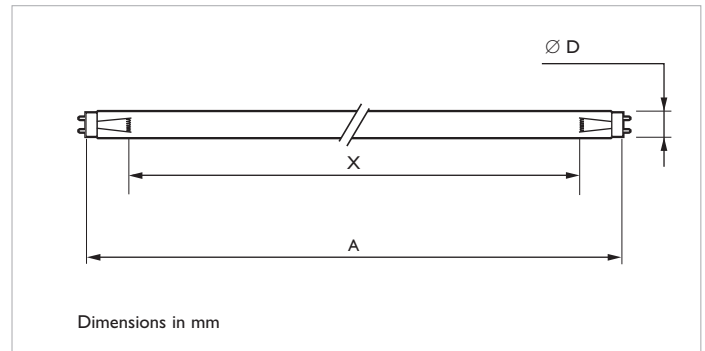

Philips TUV lamps											
Type	Cap/ base	Tube diameter max.	Arc length mm (X)	Bf - Bf mm (A)	Lamp Wattage (W)	Lamp voltage (V)	Lamp current (A)	UVC 100h (W)	µW/cm <sup>2</sup> at 1 meter	Depreciation 9000 h %	Useful lifetime h
Philips TUV 4W	G5	16.0	85	135.9	4	29	0.17	0.9	9	40	6000
Philips TUV 6W	G5	16.0	161	212.1	6	42	0.16	1.5	15	25	9000
Philips TUV 8W	G5	16.0	237	288.3	7	56	0.15	2.1	21	20	9000
Philips TUV 10W	G13	28.0	262	331.5	9	45	0.23	2.2	23	15	9000
Philips TUV 11W	G5	16.0	161	212.1	11	33	0.41	2.6	26	30	9000
Philips TUV 16W	G5	16.0	237	288.3	16	49	0.39	3.9	39	20	9000
Philips TUV F17T8	G13	28.0	526	589.8	17	72	0.27	4.5	45	20	9000
Philips TUV 25W	G5	16.0	466	516.9	28	68	0.49	8.8	88	20	9000
Philips TUV 115W RVHO	G13	40.5	1037	1199.4	115	92	1.50	33.5	610	20*	5000
Philips TUV 115WVHO	G13	40.5	1037	1199.4	115	92	1.50	38.8	360	15*	5000

\*at 5000 hours

# Philips TUV (Xtra) T8 range

The X-technology is a unique innovation by Philips, the global market leader in lighting. Purification lamps with Philips X-technology (TUV Xtra) have a lifetime that is 2 times longer than that of 'normal' TUV lamps. Philips TUV Xtra lamps are fully retrofit, long-lasting, very reliable and contribute to a better environment.

The unique X-technology from Philips also guarantees the highest lifetime reliability in the market. It is a case of 'fit and forget': after installation of the lamps, you don't have to worry about them for years to come. These lamps offer the lowest early failure rate in the market, leading to a sharp reduction in maintenance costs (and therefore a substantially lower Total Cost of Ownership) and facilitating the switch from spot to group replacement. Philips UV purification lamps have the lowest mercury content in the market - 2.0 mg in case of TUV and 3.0 mg in case of TUV Xtra lamps. Next to that The unique X-technology from Philips guarantees the highest lifetime reliability in the market (Less waste), this makes them very much environmental friendly.

Main applications:

- Residential drinking water units
- Stand alone air purifiers
- Wall-mounted air purification units



Feature	Benefit
Philips X-technology	highest reliable lifetime in the market

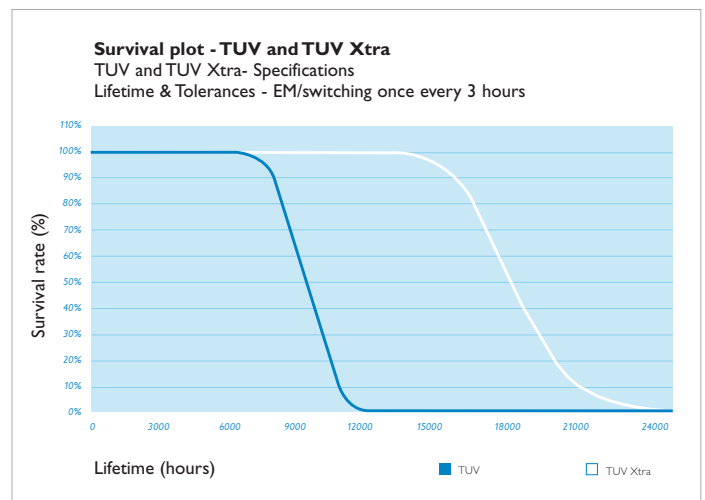
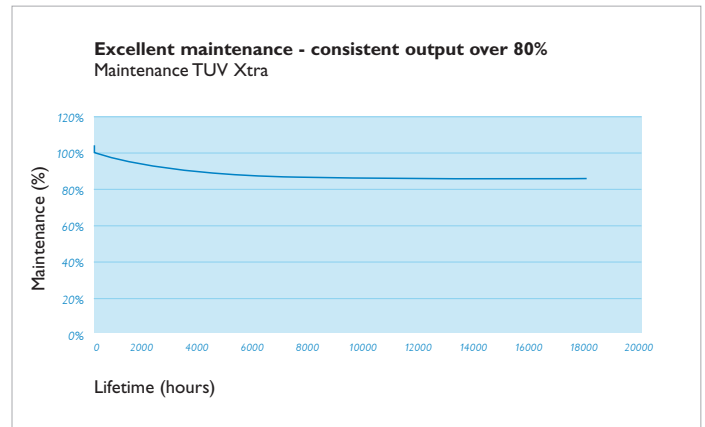

Philips TUV (Xtra) lamps with EM Ballast												
Type	Cap/ base	Tube diameter max.	Arc length mm (X)	Bf - Bf mm (A)	Lamp Wattage (W)	Lamp voltage (V)	Lamp current (A)	UVC 100h (W)	µW/cm <sup>2</sup> at 1 meter	Depreciation 9000 h %	Useful lifetime h	Useful lifetime TUV Xtra (h)
Philips TUV (Xtra) 15W	G13	28.0	373	437.4	15.9	54	0.34	4.9	47	10	9000	18000
Philips TUV (Xtra) 25W	G13	28.0	373	437.4	25.5	48	0.61	7.0	68	15	9000	18000
Philips TUV (Xtra) 30W	G13	28.0	831	894.6	30.0	100	0.37	11.5	102	10	9000	18000
Philips TUV (Xtra) 36W	G13	28.0	1135	1199.4	36.0	103	0.44	15.0	124	10	9000	18000
Philips TUV (Xtra) 55W HO	G13	28.0	831	894.6	54.0	86	0.77	17.5	156	10	9000	18000
Philips TUV (Xtra) 75W HO	G13	28.0	1135	1199.4	75.0	110	0.84	25.5	211	10	9000	18000

Philips TUV (Xtra) lamps with HF Ballast												
Type	Cap/ base	Tube diameter max.	Arc length mm (X)	Bf - Bf mm (A)	Lamp Wattage (W)	Lamp voltage (V)	Lamp current (A)	UVC 100h (W)	µW/cm <sup>2</sup> at 1 meter	Depreciation 9000 h %	Useful lifetime h	Useful lifetime TUV Xtra (h)
Philips TUV (Xtra) 15W	G13	28.0	373	437.4	14.9	45	0.33	5.1	48	10	18000	36000
Philips TUV (Xtra) 25W	G13	28.0	373	437.4	25.0	46	0.72	7.5	73	15	18000	36000
Philips TUV (Xtra) 30W	G13	28.0	831	894.6	31.0	100	0.35	13.1	116	10	18000	36000
Philips TUV (Xtra) 36W	G13	28.0	1135	1199.4	32.0	103	0.32	14.7	121	10	18000	36000
Philips TUV (Xtra) 55W HO	G13	28.0	831	894.6	55.0	86	0.84	19.6	174	10	18000	36000
Philips TUV (Xtra) 75W HO	G13	28.0	1135	1199.4	75.0	110	0.84	28.1	232	10	18000	36000

# Philips TUV T8 electronic EM and HF drivers

Next to lamps Philips is the only manufacturer that offers a complete inhouse manufactured package of lamp, driver and sleeve what gives us the possibility to optimize the delicate balance and interaction between lamp and driver. With the right driver you can optimize the energy consumption, UV output, and lifetime of the lamp. It is highly recommended to use Philips HF drivers for TUV-Xtra lamps.

Features	Benefits
Optimized for driving Philips TUV lamps	Optimal application performance
Fully automated production	High reliability and long lifetime

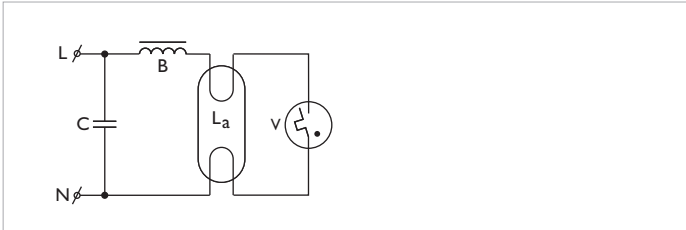

EM BALLAST

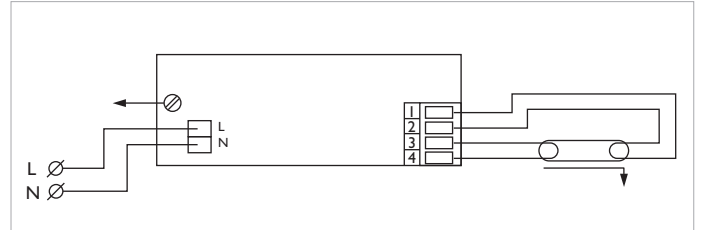

HF BALLAST

Overview		
Lamp	Ballast	Lifetime (hrs)
TUV	EM	9,000
TUV	HF	18,000
TUV Xtra	EM	18,000
TUV Xtra	HF	36,000

Lifetime expectancy TUV Xtra					
50% survival	HF Preheat	EM	90% survival	HF Preheat	EM
3h cycle IEC	36,000	18,000	3h cycle IEC	30,000	15,500
95% survival	HF Preheat	EM	97% survival	HF Preheat	EM
3h cycle IEC	29,000	15,000	3h cycle IEC	26,500	14,000

Philips TUV (Xtra) lamps EM and HF Drivers		
Type	EM Drivers	HF Drivers
Philips TUV (Xtra) 15W	BTA 15W 230V B2	HF-P 118 TLD EII
Philips TUV (Xtra) 25W	BTA 36W 230V C	HFP I 60-120 PL-H IUV-2S60-M4LD (120-277V main) - ADVANCE
Philips TUV (Xtra) 30W	BTA 30W 230V C	HF-P 136 TLD EII
Philips TUV (Xtra) 55W HO	BTA 58W 230V B2	HFP I 60-120 PL-H IUV-2S60-M4LD (120-277V main) - ADVANCE
Philips TUV (Xtra) 75W HO	BTA 36W 230V C (2*/1)	HFP I 60-120 PL-H IUV-2S60-M4LD (120-277V main) - ADVANCE

# Philips TUV low pressure PL-S and PL-L lamps

These lamps combine all the benefits listed in the previous part and have on top of that, a very compact design. This allows the possibility of a compact unit design. Another advantage is that the lamps are single ended and can be easily replaced. The HO versions are very efficient in air purification applications as they are windchill corrected. This means that in the cooling air flow the lamp will be operating at their optimal temperature range thus giving the highest efficiency. The Philips TUV PL-S lamps have specially adapted starters providing almost instant starting characteristics already built into the lamp base.

## Main applications:

- Residential drinking water
- Pond water
- In-duct air treatment units
- Stand alone air purifiers

Features	Benefits
Compact design	Small footprint for system, design flexibility
Single-ended	Easy lamp replacement
Wind-chill corrected versions	Optimal application performance, better use of lamps, fewer lamps needed

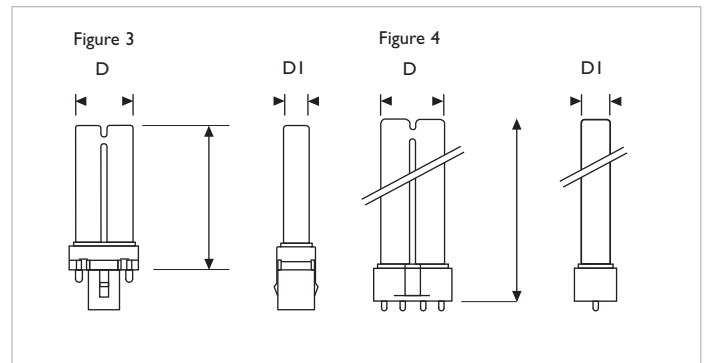
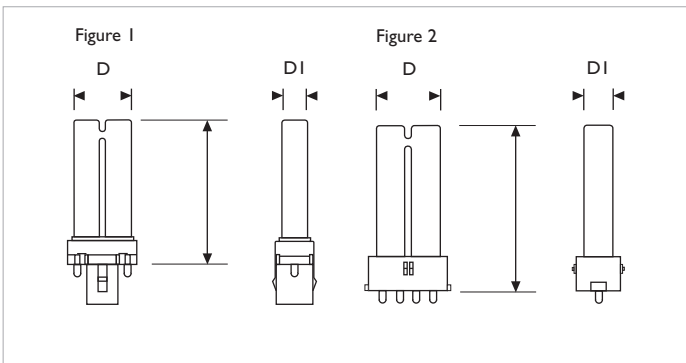

Philips TUV PL-S lamps												
Type	Cap/ base	Tube diameter max. mm (D)	Tube diameter l max. mm (DI)	Arc length mm	Bf -Te mm	Lamp Wattage (W)	Lamp voltage (V)	Lamp current (A)	UV-C 100h (W)	$\mu\text{W}/\text{cm}^2$ at 1 meter	Depreciation 9000 h %	Useful lifetime h
Philips TUV PL-S 5W 2 pin	G23	28.0	13.0 fig.1	85	82.5	5	35	0.18	1.0	9	20	9000
Philips TUV PL-S 7W 2 pin	G23	28.0	13.0 fig.1	145	112.5	7	46	0.18	1.6	15	20	9000
Philips TUV PL-S 9W 2 pin	G23	28.0	13.0 fig.1	210	144.5	9	60	0.17	2.4	22	20	9000
Philips TUV PL-S 9W 4 pin	2G7	28.0	13.0 fig.2	210	144.5	9	60	0.17	2.4	22	20	9000
Philips TUV PL-S 11W 2 pin	G23	28.0	13.0 fig.1	350	213.3	11	89	0.16	3.6	33	20	9000
Philips TUV PL-S 13W 2 pin	GX23	28.0	13.0 fig.3	230	155.2	13	56	0.29	3.4	31	20	9000
Philips TUV PL-L lamps												
Philips TUV PL-L 18W 4 pin	2G11	39.0	18.0 fig.4	325	220.0	18	58	0.37	5.5	51	15	9000
Philips TUV PL-L 24W 4 pin	2G11	39.0	18.0 fig.4	515	315.0	24	87	0.35	7.0	65	15	9000
Philips TUV PL-L 35W HO 4 pin <sup>(1)</sup>	2G11	39.0	18.0 fig.4	325	220.0	38	55	0.85	11.0	105	15	9000
Philips TUV PL-L 36W 4 pin <sup>(2)</sup>	2G11	39.0	18.0 fig.4	705	410.0	36	106	0.44	12.0	110	15	9000
Philips TUV PL-L 55W HF 4 pin <sup>(1)</sup>	2G11	39.0	18.0 fig.4	955	535.0	55	105	0.53	17.0	156	15	9000
Philips TUV PL-L 60W HO 4 pin <sup>(1) (2)</sup>	2G11	39.0	18.0 fig.4	705	410.0	65	82	0.80	19.0	235	15	9000
Philips TUV PL-L 95W HO 4 pin <sup>(1)</sup>	2G11	39.0	18.0 fig.4	955	535.0	90	115	0.80	27.0	250	15	9000

1) When used with electronic ballast 25 KHz HF

2) Lamp is also available with shatterproof SECURA sleeve



# Philips TUV low pressure lamps - T5 range

The Philips TUV T5 range uses a smaller diameter glass tube than the conventional straight tube lamps. They come in a variety of sizes, end caps and output versions. From single pin to single ended and from normal output to HO, guaranteeing that there is a suitable lamp for every application. The extreme low mercury in the lamps has allowed us to bring the first lamps on the market that are compliant to the strict TCLP regulations, and are considered as non hazardous waste.

Main applications:

- Municipal water treatment systems
- Swimming pool applications
- Residential drinking water systems
- Air treatment units

Features	Benefits
Small diameter	Small footprint for system, design flexibility
Some TCLP compliant lamps	Can be disposed as non toxic waste

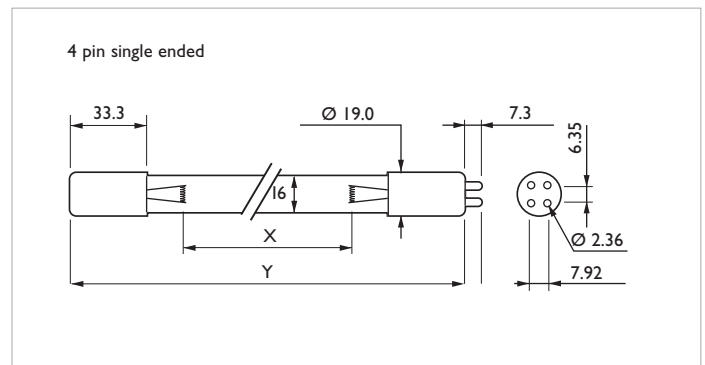
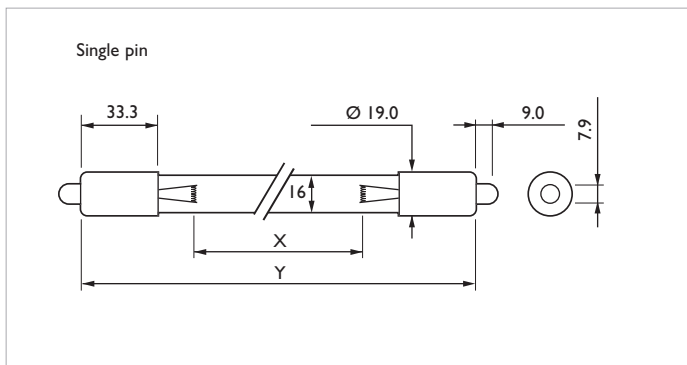

Philips TUV T5 lamps										
Type	Cap/ base	Arc length mm (X)	Bf - Bf mm (Y)	Lamp Wattage (W)	Lamp voltage (V)	Lamp current (A)	UV-C 100h (W)	$\mu\text{W}/\text{cm}^2$ at 1 m	Depreciation 9000 hr %	Useful lifetime h
Philips TUV 36 T5 SP*	single pin	762	842.4	40	94	0.43	15.0	144	15	9000
Philips TUV 64 T5 SP*	single pin	1473	1553.6	75	176	0.43	31.0	280	15	9000
Philips TUV 64 T5 HO SP*	single pin	1459	1553.6	145	175	0.80	48.0	442	20	9000
Philips TUV 11W 4P-SE**	4 pin single ended	161	241.1	11	33	0.41	2.6	26	30	9000
Philips TUV 16W 4P-SE**	4 pin single ended	237	317.3	16	49	0.39	3.9	39	20	9000
Philips TUV 25W 4P-SE**	4 pin single ended	466	545.9	28	68	0.49	8.8	88	20	9000
Philips TUV 36 T5 4P-SE*	4 pin single ended	762	842.4	40	94	0.43	15.0	144	15	9000
Philips TUV 36 T5 HO 4P-SE*	4 pin single ended	748	842.4	75	97	0.80	25.0	230	20	9000
Philips TUV 64 T5 4P-SE*	4 pin single ended	1473	1553.6	75	176	0.43	31.0	280	15	9000
Philips TUV 64 T5 4P-SE CS*	4 pin single ended	1473	1553.6	75	176	0.43	31.0	280	15	9000
Philips TUV 64 T5 HO 4P-SE*	4 pin single ended	1459	1553.6	145	175	0.80	48.0	442	20	9000

\* When used with electronic ballast 25 KHz HF

\*\* When used with conventional magnetic ballast 50 Hz

# Philips TUV medium pressure mercury lamps

We manufacture and internationally distribute a wide range of high quality medium pressure mercury UV lamps. These quartz lamps are available up to 180 Watts per cm, with an arc length of 4 to 140 cm, in a variety of end fittings. The lamps are made from selected types of quartz glass, manufactured at our own factories.

## Medium pressure mercury UV lamps

Our medium pressure lamps contain sophisticated quantities of mercury bromides, providing a self-cleaning halogen cycle, to control the decline of UV radiation over lamplife.

Main applications:

- Municipal waste water treatment systems
- Municipal drinking water treatment systems
- Process water treatment systems
- Swimming pool treatment systems

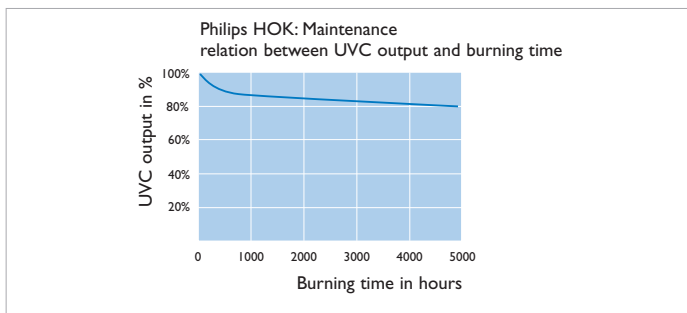

## Spectral output

The lamps emit the characteristic spectrum of mercury discharge lamps. The HOK and HTK types also radiate wavelengths below 240 nm, whereby ozone is formed. The special quartz of the HTQ lamps absorbs radiation below 240 nm. To maximize the 185nm radiation we can also produce lamps the lamps from open or synthetic quartz.

Features	Benefits
Self cleaning halogen cycle	Better maintenance of lamps, no over-designing necessary, cost saving.
Lamp can be made from special quartz (open/synthetic)	Maximizes 185nm Ozone generation

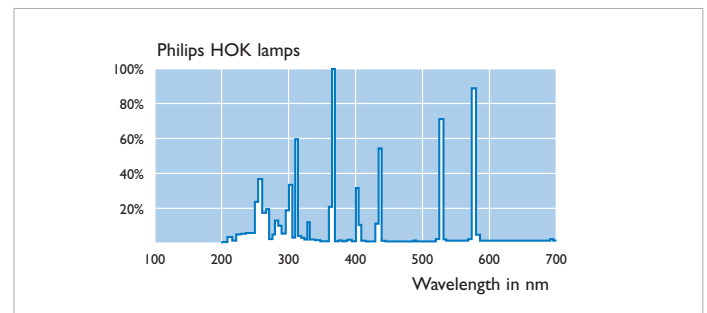

Philips HOK lamps										
Type	Tube diameter length	Arc length mm (X)	Lamp wattage (W)	Lamp voltage (V)	Overall lamp length (Y)	Lamp current (A)	UVC >210 nm (W)	UVB (W)	UVA (W)	μW/cm <sup>2</sup> at 1 meter
Philips HOK 4/120	14	29	400	125	104.0	3.5	53	32	31	488
Philips HOK 4/120 SE*	14	29	400	125	110.0	3.5	53	32	31	488
Philips HOK 20/100	22	195	2000	245	262.0	9.6	325	198	175	2990
Philips HOK 35/120	22	348	4300	510	428.0	10.3	759	403	351	6983
Philips HOK 50/120	22	500	6000	1050	580.0	10.0	1060	546	462	9752
Philips HOK 65/120	22	637	7800	910	717.0	10.3	1278	741	722	11758
Philips HOK 80/120	22	800	9600	1080	880.0	10.5	1568	926	829	14426
Philips HOK 105/120	22	1057	12400	1430	1137.0	10	2021	1244	1042	18593
Philips HOK 140/120	22	1407	17000	1920	1487.0	10.0	2860	1646	1380	26312
Philips HTK 7/60	14	700	4000	1400	770.0	3.1	593	380	321	5456
Philips HTQ 7	14	700	2000	1400	762.5	1.7	130	165	142	1196
Philips HTQ 14	22	1400	4000	1400	1485.0	3.1	280	350	300	2576
Philips HOK 10/120L	22	106	1000	145	232.0	7.5	135	80	80	1250
Philips HOK 15/120L	22	151	1450	150	277.0	10.0	185	135	128	1720
Philips HOK 20/120L	22	204	2000	240	332.0	9.7	280	180	175	2570
Philips HOK 25/120L	22	254	2800	275	382.0	10.0	466	280	255	4290

\* SE = single ended

**Note:** Permissible bulb temperatures: HOK: 600 - 900°C HTK, HTQ: 500 - 700°C

Permissible pinch temperatures: 300°C

\*Higher pinch temperatures up to 420°C are possible using the Philips patented Pinch Protection

**We can also assist you with tailor made solutions**

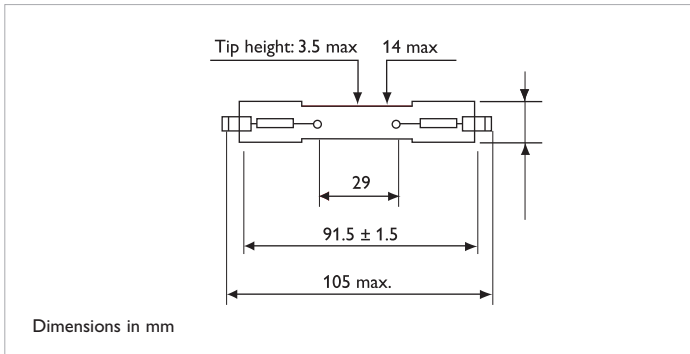

Philips HOK 4/120

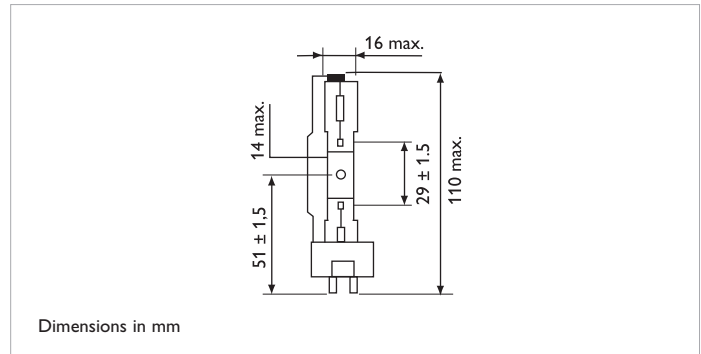

Philips HOK 4/120 SE

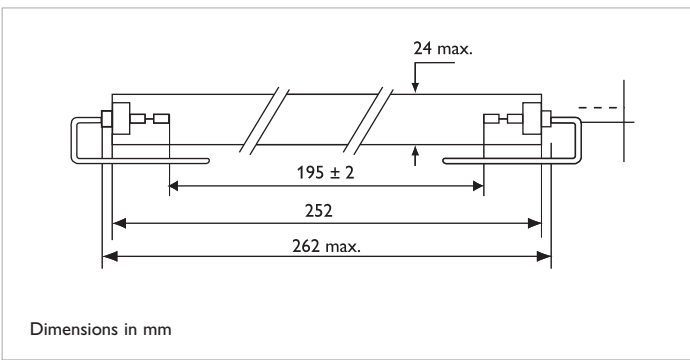

Philips HOK 20/100

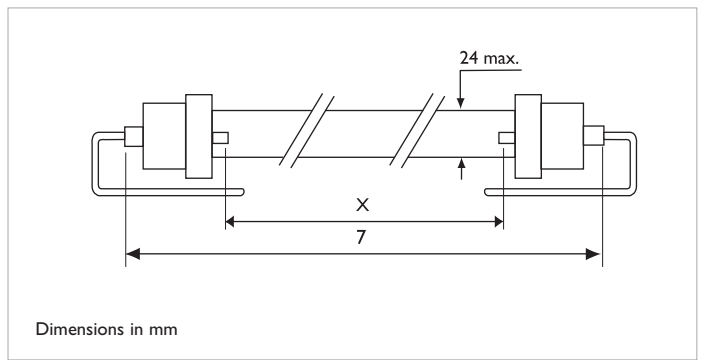

Philips HOK 35/120, HOK 50/120, HOK 65/120, HOK 80/120, Philips HOK 105/120, HOK 140/120

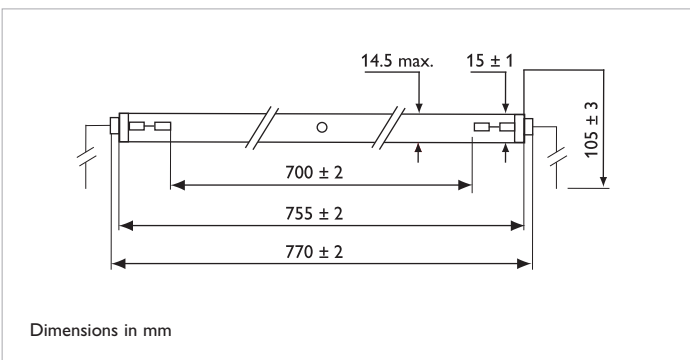

Philips HTK 7/60

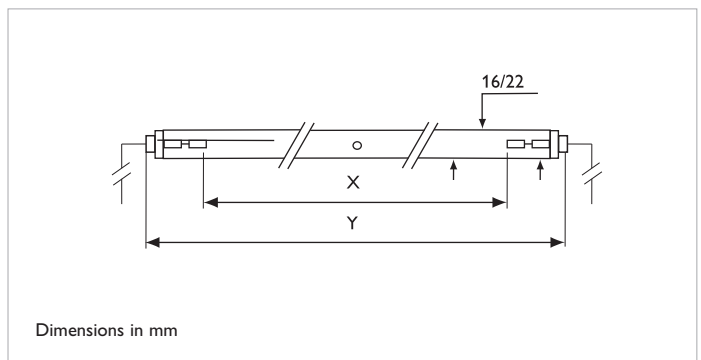

Philips HTQ 7, HTQ 14

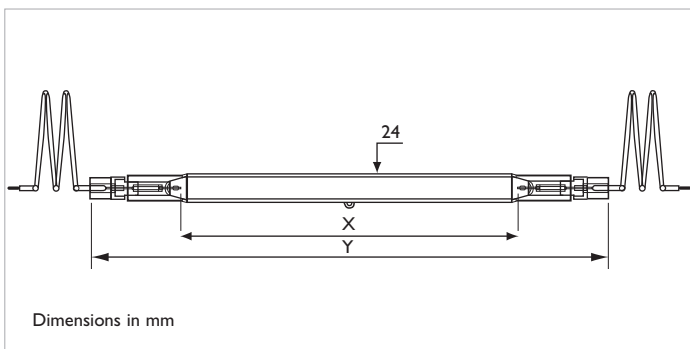

Philips HOK 10/120L, HOK 15/120L, HOK 20/120L, HOK 25/120L

**Note:** please contact us for details on dimensions and tolerances.

# Philips TUV extreme power technology amalgam lamps

Philips amalgam lamps combine the advantages of the low pressure and the medium pressure lamp. This fills the gap between the low pressure and medium pressure applications. The amalgam lamp combines high efficiencies with relative high power densities operating in a broad temperature range.

By using our long history of lamp development we offer a lamp with a very high UVC efficiency. By applying our patented coating technology we are able to guarantee a maintenance of 85% after 12000 hours operating in a broad temperature range.

Our special amalgam gives a broader temperature range in which lamps operate most efficiently.

Main applications:

- Municipal drinking water treatment systems
- Municipal waste water treatment systems
- Process water treatment units
- Swimming pool treatment systems

## eXtreme Power Technology (XPT) amalgam lamps

This cutting edge technology allows high wattage in all low pressure lamps, resulting in amazing power.

### Please contact us for tailor made solutions

Features	Benefits
Philips driver available	Optimized performance
Special amalgam used	Highest efficiency in broader temperature range, allowing greater flexibility in system design and application
Lamp can be made from special quartz (open/synthetic)	Maximizes 185nm Ozone generation
Coating inside	Low UVC depreciation so over-designing the system can be limited to the bare minimum
Lowest mercury level	More environmentally friendly

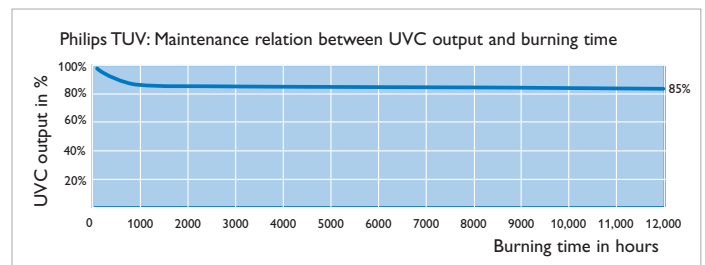
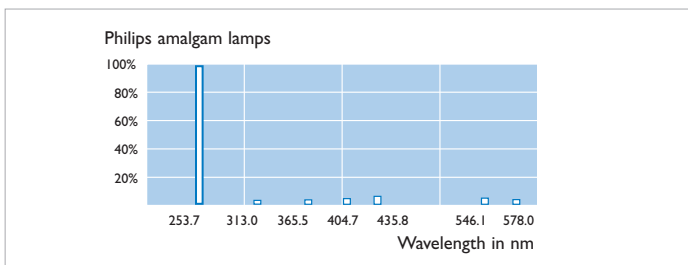

Philips amalgam lamps										
Type T12*	Cap/base	Tube diameter (A)	Arc length mm (B)	Basephase max mm (C)	Lamp Wattage (W)	Lamp voltage (V)	Lamp current (A)	UVC 100h (W)	Maintenance 12000 h %	Useful lifetime h
Philips TUV 800W XHO**	t.b.d.	38.0	1600	t.b.d.	800	100	8.0	>240	85	12.000
<b>Type T10</b>										
Philips TUV 330W XPT	4p-SE	32.0	1440	1560	325	72	4.6	107	85	12.000
Philips TUV 270W XPT	DE	32.0	1440	1560	268	78	3.5	100	85	12.000
<b>Type T8</b>										
Philips TUV 250W XPT	4p-SE	25.5	1410	1510	255	83	3.1	90	85	12.000
<b>Type T6</b>										
Philips TUV 325W XPT HO	4p-SE	19.0	1480	1580	325	158	2.0	110	85	12.000
Philips TUV 325W XPT	4p-SE	19.0	1480	1580	280	141	2.0	100	85	12.000
Philips TUV 200W XPT	4p-SE	19.0	1045	1145	200	100	2.0	66	85	12.000
Philips TUV 180W XPT	4p-SE	19.0	937	1037	180	90	2.0	60	85	12.000
Philips TUV 130W XPT	4p-SE	19.0	740	840	140	70	2.0	48	85	12.000

\* Electrical values depend on power supply. \*\* TUV 800W XHO is a design-in product. Contact us for tailor made solutions.

# Philips ozone generating lamps

Ozone is one of the most powerful oxidants known and the naturally occurring level not only protects all life from the harmful effects of solar ultraviolet radiation but also is very effective at destroying bacteria, viruses and chemicals.

Philips ozone generating lamps are effective in producing the very precise wavelength of electromagnetic radiation required in this process, eliminating harmful substances and pollutants. That is why Philip's ozone lamps are ideal across a range of applications, from swimming pools to water treatments.

Main applications:

- Ultra Pure process water treatment systems
- Swimming pool and spa water treatment units
- Total Organic Compound (TOC) reducing applications
- In duct air treatment units
- Advanced Oxidation, combined with H<sub>2</sub>O<sub>2</sub>

Features	Benefits
Ability to generate 185nm	Ability to select most optimal lamp per application
Special coating inside XPT ozone lamps	Special coating inside XPT ozone lamps
Philips driver available	Optimized performance

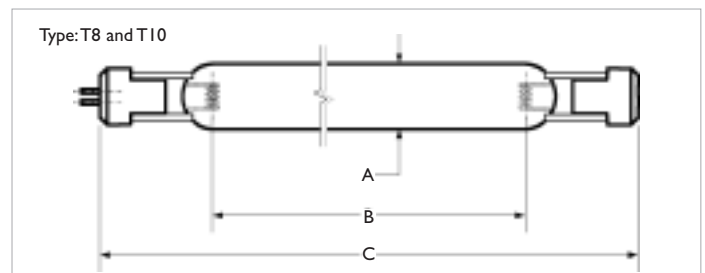
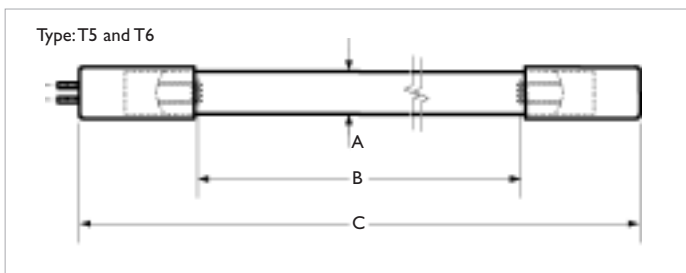
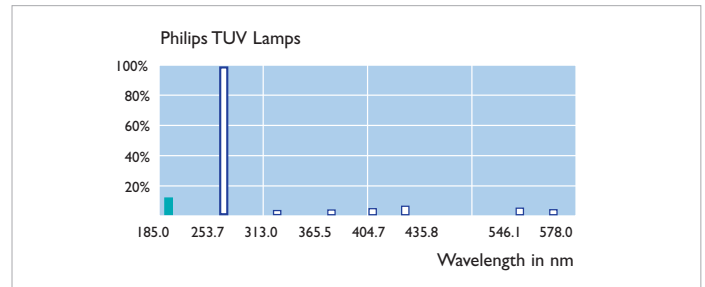

Philips TUV XPT ozone lamps											
Type T10	Cap/base	Tube diameter (A)	Arc length mm (B)	Basephase max mm (C)	Lamp Wattage (W)	Lamp voltage (V)	Lamp current (A)	254nm UVC 100h (W)	185 nm UVC 100h (W)	Maintenance 12.000 h %	Useful lifetime h
Philips TUV 330W XPT ozone	4p-SE	32.0	1440	1560	325	72	4.6	*	13.9	70	12.000
Philips TUV 270W XPT ozone	DE	32.0	1440	1560	268	78	3.5	*	13.0	70	12.000
Type T8											
Philips TUV 250W XPT ozone	4p-SE	25.5	1410	1510	255	83	3.1	*	11.7	70	12.000
Type T6											
Philips TUV 325W XPT ozone	4pin SE	19.0	1480	1580	280	141	2.0	*	13.0	70	12.000
Philips TUV 240W XPT ozone	4pin SE	19.0	1480	1600	243	134	1.8	*	11.2	70	12.000
Philips TUV 130W XPT ozone	4pin SE	19.0	740	840	146	71	2.1	*	6.5	70	12.000
Philips TUV ozone lamps											
Type T5	Cap/base	Tube diameter (A)	Arc length mm (B)	Basephase max mm (C)	Lamp Wattage (W)	Lamp voltage (V)	Lamp current (A)	254nm UVC 100h (W)	185 nm UVC 100h (W)	Maintenance 9.000 h %	Useful lifetime h
Philips Ozone 762/T5/2p SE/s	2pin SE	15.0	762	843	40	90	0.45	20	2.0	45	9.000
Philips Ozone 762/T5/4p SE/s	4pin SE	15.0	762	843	40	90	0.45	20	2.0	45	9.000
Philips Ozone 1474/T5/2p SE/s	2pin SE	15.0	1474	1554	73	180	0.45	40	4.0	45	9.000
Philips Ozone 1474/T5/4p SE/s	4pin SE	15.0	1474	1554	73	180	0.45	40	4.0	45	9.000

Electrical values depend on power supply. \* Information available on request.

We can also assist you with tailor made solutions

# Philips TUV amalgam electronic drivers

Philips Lighting amalgam systems are being developed with the main municipal purification requirements in mind: high reliability, optimized lamp-ballast solution and high efficiency.

The printed circuit board with electronic components replaces the traditional copper/iron drivers. By using electronic rather than magnetic drivers, power losses are considerably reduced. By using our long history of electronic driver development we are able to design the most reliable drivers in the market. Our dedicated driver team is able to manufacture a driver with the right features customized to your specific application. By potting our drivers, our electronics will also survive in condensing and aggressive environments.

Features	Benefits
Optimized for driving Philips amalgam lamps	Optimal application performance
Fully controlled production	High reliability and long lifetime
Worldwide certifications	Drivers can be used worldwide
Patented IC Chip	Stable performance and special functions

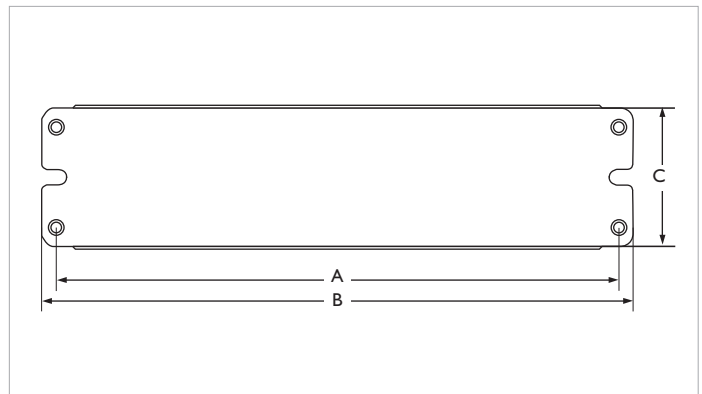
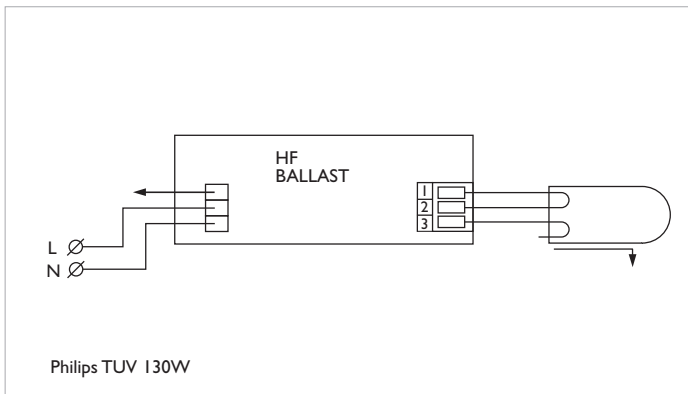

Philips TUV amalgam drivers										
Type	A (mm)	B (mm)	C (mm)	Line Frequency (Hz)	Main input (V)	Number of lamps	Lamp Power (W)	Driver efficiency	Useful lifetime h	Preheated/dimmable
Philips TUV 130W amalgam driver	283	297	69.4	50/60	110 - 240	1	140	>92%	> 50.000	no
Philips TUV 180W amalgam driver	283	297	69.4	50/60	110 - 240	1	180	>92%	> 50.000	yes
Philips TUV 200W amalgam driver	283	297	69.4	50/60	110 - 240	1	200	>92%	> 50.000	yes
Philips TUV 325W (HO) amalgam driver	283	297	69.4	50/60	110 - 240	1	280 - 325	>92%	> 50.000	yes
Philips TUV 800W amalgam driver	prototype			50/60	110 - 240	1	800	>92%	> 50.000	yes

**Note:** Philips TUV 800W amalgam driver is currently under development. Please contact us for more information. For lamp operating parameters please see Philips TUV extreme power technology amalgam lamps.

Driver features available on request like dimming, pre-heat, interfacing and remote control

# Philips quartz sleeves

Philips quartz realizes that UVC output is the most important product parameter for your UV and germicidal applications. Therefore we give continuous attention to control and improve the transmittance of our Ph 300 clear fused quartz.

We offer a broad range of sleeves, which are designed for Philips UV lamps. It is this perfect fit of lamp and sleeve which guarantees an excellent performance in your systems. Our sleeves are flame polished and can be closed at one end. The flame polished ends prevent breakage during handling. The resistance to pressure is max. 2700 PSI. Our sleeves are recognized for their constant and world-class quality and therefore applied by OEM industry leaders.

Especially for drinking water applications we developed Ph 300 Quartz sleeves. Ph 300 is the world-class quality standard on UVC transmittance at 253,7 nm.

Features	Benefits
Ideal fit with Philips UV lamps	High quality performance and long lifetime
Flame polished	No breakage during system assembly operations

## Transmittance data Ph 300 clear fused quartz, n = > 100 samples.

Parameter	Typical value @ 253,7nm *	Specification @ 253,7nm	Unit
Absorption coefficient - Ph 300	0.142	0.332	cm <sup>-1</sup>
Transmittance Ph 300	90.7	89.0	%

\*Transmittance measured at 1 mm wall thickness including surface reflection losses.

## UV Transmittance Ph 300 clear fused quartz

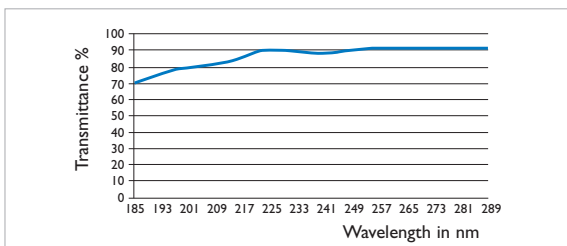
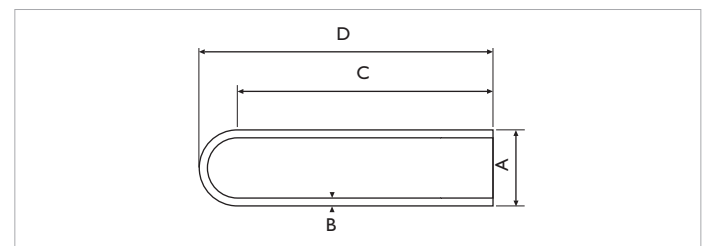

Figure 1: Transmittance curve Ph 300 clear fused quartz, n = > 100 samples.



## Product range dimensions

Philips Sleeves for T5 lamps					
Type	Outer diameter (mm)*	Outer diameter open end (mm) A *	Wall thickness (mm) B	Straight length (mm) C	Length incl. closed end (mm) D
Philips TUV 4P-SE 11W	25 ± 0,38	25 ± 0,58	1,2 ± 0,10	225 ± 2,0	240 ± 2,0
Philips TUV 4P-SE 16W	25 ± 0,38	25 ± 0,58	1,2 ± 0,10	300 ± 2,0	315 ± 2,0
Philips TUV 4P-SE 25W	25 ± 0,38	25 ± 0,58	1,2 ± 0,10	530 ± 2,0	545 ± 2,0
Philips TUV T5 4P-SE 36 HE&HO	25 ± 0,38	25 ± 0,58	1,2 ± 0,10	885 ± 2,0	900 ± 2,0
Philips TUV T5 4P-SE 64 HE&HO	25 ± 0,38	25 ± 0,58	1,2 ± 0,10	1585 ± 2,0	1600 ± 2,0
Philips Sleeves for amalgam lamps					
Philips T6 TUV XPT 130W	28 ± 0,42	28 ± 0,62	1,5 ± 0,12	885 ± 2,0	900 ± 2,0
Philips T6 TUV XPT 180W	28 ± 0,42	28 ± 0,62	1,5 ± 0,12	1105 ± 2,0	1120 ± 2,0
Philips T6 TUV XPT 325W	28 ± 0,42	28 ± 0,62	1,5 ± 0,12	1625 ± 2,0	1640 ± 2,0
Philips T10 TUV XPT 330W	44 ± 1,32	44 ± 1,52	1,6 ± 0,16	1625 ± 2,0	1640 ± 2,0
Philips Sleeves for PLS lamps (=SE)					
Philips TUV G23 PL-S 5W, 7W/9W	31 ± 0,62	31 ± 0,82	1,2 ± 0,12	129 ± 2,0	145 ± 2,0
Philips TUV G23 PL-S 11W/13W	31 ± 0,62	31 ± 0,82	1,2 ± 0,12	129 ± 2,0	214 ± 2,0
Philips Sleeves for PLL lamps (=SE)					
Philips TUV 2G11 PL-L 18W/35W HO	44 ± 1,32	44 ± 1,52	1,6 ± 0,16	195 ± 2,0	217 ± 2,0
Philips TUV 2G11 PL-L 36W/60W HO	44 ± 1,32	44 ± 1,52	1,6 ± 0,16	385 ± 2,0	407 ± 2,0
Philips TUV 2G11 PL-L 55W HF/95W HO	44 ± 1,32	44 ± 1,52	1,6 ± 0,16	505 ± 2,0	527 ± 2,0

Table 1: Product range Ph 300 clear fused quartz, sleeves.

\* incl. tolerances of fire polishing

# Circuit information

## Supply Voltage 230V (50Hz)

Type	# Lamps	Starter	*Capacitor (uF)	Electromagnetic ballast <sup>1) 2)</sup>	EOC	Circuit Number (Page 15)		
Philips TUV 4W	T5	1	S2	2.0 paral.	BTL 8W 230V B2	928122 30	1	
		2	2*S2	2.0 paral.	BTL 8W 230V B2	928122 30	2	
Philips TUV 6W	T5	1	S2	2.0 paral.	BTL 8W 230V B2	928122 30	1	
		2	2*S2	2.0 paral.	BTL 13W 230V B2	928245 30	2	
Philips TUV 8W	T5	1ft	1	S2	2.0 paral.	BTL 8W 230V B2	928122 30	1
			1	S2	2.0 paral.	BTL 13W 230V B2	928245 30	1
			2	2*S2	1.6 paral.	BTL 13W 230V B2	928245 30	2
Philips TUV 11W	T5	1	S10	4.5 paral.	BTL 8W 230V B2 (2*/I)	928122 30	1	
		1	S10	4.5 paral.	BTA 18W 230V C	919120 30	1	
Philips TUV 16W	T5	1ft	1	S10	4.5 paral.	BTA 18W 230V C	919120 30	1
			2	2*S2	4.5 paral.	BTA 30W 230V C	919151 30	2
Philips TUV 25W	T5	1	S10	4.5 paral.	BTA 18W 230V C	919120 30	1	
Philips TUV 10W	T8	1	S10	2.0 paral.	BPL 18W 230V B2	928306 30	1	
Philips TUV 15W	T8	1	S10	4.5 paral.	BTA 15W 230V B2	919106 30	1	
Philips TUV 25W	T8	1	S10	4.5 paral.	BTA 36W 230V C	919175 30	1	
Philips TUV 30W	T8	3ft	1	S10	4.5 paral.	BTA 30W 230V C	919151 30	1
Philips TUV 36W	T8	4ft	1	S10	4.5 paral.	BTA 36W 230V C	919175 30	1
Philips TUV 55W HO	T8	3ft	1	S10	6.5 paral.	BTA 58W 230V B2	919229 30	1
Philips TUV 75W HO	T8	4ft	1	S12	2 x 4.5 paral.	BTA 36W 230V C (2*/I)	919175 30	5
			1	S12		VS L80.397	Vossloh-Schwabe	1
Philips TUV 115W VHO	T12	4ft	1	CP	2 x 9 paral.	VS L140 UV 799	Vossloh-Schwabe	1
			1	S12	2 x 4.5 paral.	BTA 58W 320V B2 (2*/I)	919229 30	5
Philips TUV 11W 4P-SE	T5	1	S10	4.5 paral.	BTL 8W 230V B2 (2*/I)	919122 30	1	
		1	S10	4.5 paral.	BTA 18W 230V C	919120 30	1	
Philips TUV 16W 4P-SE	T5	1	S10	4.5 paral.	BTA 18W 230V C	919120 30	1	
		2	2*S2	4.5 paral.	BTA 30W 230V C	919151 30	2	
Philips TUV 25W 4P-SE	T5	2ft	1	S10	4.5 paral.	BTA 36W 230V C	919175 30	1
Philips TUV 36T5 4P-SE	T5	3ft	1	S10	4.5 paral.	BTA 36W 230V C	919175 30	1
Philips TUV 36T5 HO 4P-SE	T5	3ft	1	S10	9 paral.	VS L80.397	Vossloh-Schwabe	1
Philips TUV PL-S 5W 2P		1	N.A.		BPL 11W 230V B1	928184 30	3	
		2	N.A.		BPL 11W 230V B1	928184 30	4	
Philips TUV PL-S 7W 2P		1	N.A.		BPL 11W 230V B1	928184 30	3	
		2	N.A.		BLT 13W 230V B2	928245 30	4	
Philips TUV PL-S 9W 2P		1	N.A.		BPL 11W 230V B1	928184 30	3	
		2	N.A.		BLT 13W 230V B2	928245 30	4	
Philips TUV PL-S 11W 2P		1	N.A.		BPL 11W 230V B1	928184 30	3	
Philips TUV PL-L 18W 4P		1	S10	4.5 paral.	BTA 18W 230V C	919120 30	1	
		2	2*S2	4.5 paral.	BTA 36W 230V C	919175 30	2	
Philips TUV PL-L 24W 4P		1	S10	4.5 paral.	BTA 30W 230V C	919151 30	1	
Philips TUV PL-L 36W 4P		1	S10	4.5 paral.	BTA 36W 230V C	919175 30	1	
Philips TUV PL-L 60W HO 4P		1	S10	6.5 paral.	BTA 58W 230V B2	919229 30	1	

N.A. Starter is implemented

CP 100-180W Philips Cleo Power bimetal starter

\*Voltage values for Capacitors: Parallel: 250Vrms, series: 450Vrms

1) To support the existing lamp types as listed for special lighting applications, the specified ballast types are approved for use in special lamp-ballast combinations. Because these ballasts are not specially designed for operating the listed lamp types, the applicability of these solutions is not guaranteed for the future. Despite our efforts to ensure backwards-compatibility, the specifications of the future ballast types may change so that these no longer support the special lamp as listed.

2) We will publish written notifications when such changes occur, resulting in the inability to support specific lamp-ballast combinations.



## Supply Voltage 230V (50Hz)

Type	# Lamps	Electronic ballast	EOC	Circuit Number (Page 15)
Philips TUV 4W T5	1	HF-MboxBLUE 105 TL/PL-S (square / linear)	53672330 / 53678530	6
Philips TUV 6W T5	1	HF-MboxBLUE 109 TL/PL-S (square / linear)	53674730 / 53680830	6
Philips TUV 8W T5 1ft	1	HF-MboxRED 109 TL/PL-S (square)	93142930	6
Philips TUV 11W T5	1	HFP 1 24-39 TL5 HO	928573	6
	2	HFP 2 24-39 TL5 HO	928658	7
Philips TUV 16W T5 1ft	1	HFP 1 24-39 TL5 HO	928573	6
	2	HFP 2 24-39 TL5 HO	928658	7
Philips TUV 25W T5	1	HFP 1 24-39 TL5 HO	928573	6
	2	HFP 2 24-39 TL5 HO	928658	7
Philips TUV 10W T8	1	HF-P 118 PL-T/C	74939030	6
Philips TUV 15W T8	1	HF-P 118 TLD E11	93408630	6
	2	HF-P 218 TLD E11	93413030	7
Philips TUV 25W T8	1	HFP 1 60-120 PL-H	92875731	6
Philips TUV 30W T8 3ft	1	HF-P 136 TLD E11	93146730	6
Philips TLD 36W T8 4ft	1	HF-P 136 TLD E11	93146730	6
	2	HF-P 236 TLD E11	93150430	7
Philips TUV 55W HO T8 3ft	1	HFP 1 60-120 PL-H	92875731	6
	1	IUV-2S60-M4LD (120-277V main)	ADVANCE	6
Philips TUV 75W HO T8 4ft	1	HFP 1 60-120 PL-H	92875731	6
	1	IUV-2S60-M4LD (120-277V main)	ADVANCE	6
Philips TUV 115WVHO T12 4ft	1	EVG 1.4-1.5A (Instant Start four wires)	ZED Germany	6
Philips TUV 11W 4P-SE T5	1	HFP 1 24-39 TL5 HO	928573	6
	2	HFP 2 24-39 TL5 HO	928658	7
Philips TUV 16W 4P-SE T5	1	HFP 1 24-39 TL5 HO	928573	6
	2	HFP 2 24-39 TL5 HO	928658	7
Philips TUV 25W 4P-SE T5 2ft	1	HFP 1 24-39 TL5 HO	928573	6
	2	HFP 2 24-39 TL5 HO	928658	7
Philips TUV 36T5 4P-SE T5 3ft	1	HF-B 158 TLD E11	93156630	6
	1	HFPI 54 TL5 HO	928610	6
	1	HF-P 136 TLD E11	93146730	6
Philips TUV 36T5 HO 4P-SE T5 3ft	1	HFP 1 60-120 P-LH	92875731	6
	1	IUV-2S60-M4LD (120-277V main)	ADVANCE	6
Philips TUV 64T5 4P-SE T5 5ft	1	HFPI 54 TL5 HO	928610	6
Philips TUV 64T5 HO 4P-SE	1	IUV-2S60-M4LD (120-277V main)	ADVANCE	6
Philips TUV PL-S 9W 4P	1	HF-MboxBLUE 109 TL/PL-S (square / linear)	53674730 / 53680830	8
	1	HF-MboxRED 109 TL/PL-S (square)	93142930	8
Philips TUV PL-L 18W 4P	1	HF-P 1 18-24 PL-L	749376	8
	2	HF-P 2 18-24 PL-L	749703	9
Philips TUV PL-L 24W 4P	1	HF-P 1 18-24 PL-L	749376	8
	2	HF-P 2 18-24 PL-L	749703	9
Philips TUV PL-L 35W HO 4P	1	HF-P 1 60-120 PL-H	92875731	8
	1	IUV-2S60-M4LD (120-227V main)	ADVANCE	8
	2	IUV-2S60-M4LD (120-277V main)	ADVANCE	9
Philips TUV PL-L 36W 4P	1	HF-P 136 PL-L E11	934178 30	8
	2	HF-P 236 PL-L E11	934253 30	9
Philips TUV PL-L 55W HF 4P	1	HF-P 155 PL-L E11	934239 30	8
	2	HF-P 255 PL-L E11	934291 30	9
Philips TUV PL-L 60W HO	1	HF-P 1 60-120 PL-H	92875731	8
	1	IUV-2S60-M4LD (120-277V main)	ADVANCE	8
	2	IUV-2S60-M4LD (120-277V main)	ADVANCE	9
Philips TUV PL-L 95W HO	1	HF-P 1 60-120 PL-H	92875731	8
	1	IUV-2S60-M4LD (120-277 main)	ADVANCE	8

## Supply Voltage 120V (60Hz)

Type	Base-face length (mm)	# Lamps	Electromagnetic ballast <sup>1) 2)</sup> Advance Transformers Co.	Electronic ballast <sup>1) 2)</sup> Advance Transformers Co.
Philips TUV 4W = F4T5 T5	136	1	LPL-5-9	RMB-IP13-S1
Philips TUV 6W = F6T5 T5	212	1	LC-4-9-C	RMB-IP13-S1
Philips TUV 8W = F8T5 T5 1ft	288	1	LPL-5-9	RMB-IP13-L2
		1	LPL-7-9	
		1	LC-4-9-C	
		2		RMB-2P13-L2
Philips TUV 11W = F11T5 T5	212	1	LC-14-20-C	
Philips TUV 16W = F16T5 T5 1ft	288	1	LC-14-20-C	RMB-2P13-L2
Philips TUV 25W = F25T5 T5	517	1		
Philips TUV 10W = F10T8 T8	332	1		
Philips TUV 15W = F15T8 T8 18"	437	1	LO-13-22	REL2P32-SC
		1	LC-14-20-C	
		1	L-120F	
Philips TUV 25W T8 18"	437	1		
Philips TUV F17T8 T8 2ft	590	1	RCN-1P32	REL IP32-SC
Philips TUV 30W = F30T8 T8 3ft	895	1		REL 2P30G
Philips TUV 36W T8 4ft	1199	1		REL 1S40-SC
		2		REL 2S40-SC
Philips TUV 55W HO T8 3ft	895	1		IUV-2S60-M4LD (120-277 main)
Philips TUV 75W HO T8 4ft	1199	1		IUV-2S60-M4LD (120-277 main)
Philips TUV 115W VHO T12 4ft	1199	1	RC2S102-TP	
Philips TUV 36T5 SP T5 3ft	842	1		ICN2S39
Philips TUV 36T5 4P-SE T5 3ft	842	1		IUV-2S60-M4LD (120-277 main)
Philips TUV 36T5 HO 4P-SE T5 3ft	842	1		REL IP64IS
		2		REL 2P64IS
Philips TUV 64T5 SP T5 5ft	1554	1		ICN1S80
Philips TUV 64T5 4P-SE T5 5ft	1554	1		IUV-2S60-M4LD (120-277 main)
Philips TUV PL-S 9W 2P	145	1	LPL-5-9-TP	
		1	LC-4-9-C-TP	
Philips TUV PL-S 9W 4P	145	1		RMB-IP13-L2
		1		RMB-IP13-S1
Philips TUV PL-S 11W 2P	214	1	N.A.	
Philips TUV PL-S 13W 2P	155	1	LC-13-TP	
		1	LO-13-22-TP	
Philips TUV PL-L 18W 4P	218	1	LC-25-TP	RMB-2P13-L2
		2		RMB-2P13-S2
Philips TUV PL-L 24W 4P	315	1		R-1BP27-TP
Philips TUV PL-L 35W HO 4P	218	1		IUV-2S60-M4LD (120-277 main)
		2		IUV-2S60-M4LD (120-277 main)
Philips TUV PL-L 36W 4P	408	1	R-1BP39-TP	REL-1TTS39
		1		ICN2S24
		2	R-2BS39-TP	REL-2TTS39
		2		ICN2S54
Philips TUV PL-L 55W HF 4P	528	1		ICN1S80
Philips TUV PL-L 60W HO 4P	408	1		REL2S110
		1		IUV-2S60-M4LD (120-277 main)
		2		IUV-2S60-M4LD (120-277 main)
Philips TUV PL-L 95W HO 4P	528	1		IUV-2S60-M4LD (120-277 main)

1) To support the existing lamp types as listed for special lighting applications, the specified ballast types are approved for use in special lamp-ballast combinations. Because these ballasts are not specially designed for operating the listed lamp types, the applicability of these solutions is not guaranteed for the future. Despite our efforts to ensure backwards-compatibility, the specifications of the future ballast types may change so that these may no longer support the special lamp as listed.

2) We will publish written notifications when such changes occur, resulting in the inability to support specific lamp-ballast combinations.

# Wiring diagrams

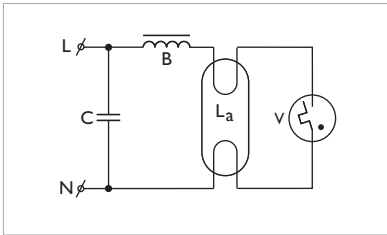

Circuit 1

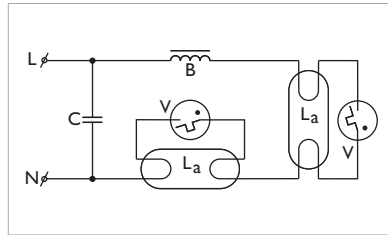

Circuit 2

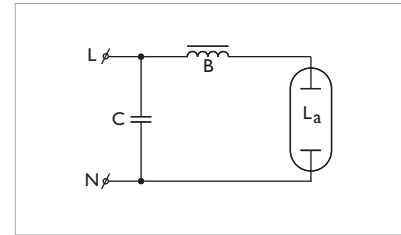

Circuit 3

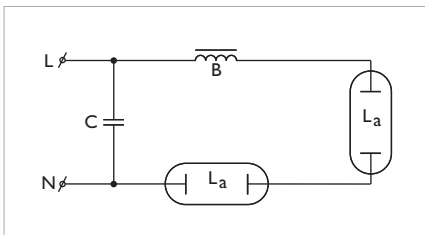

Circuit 4

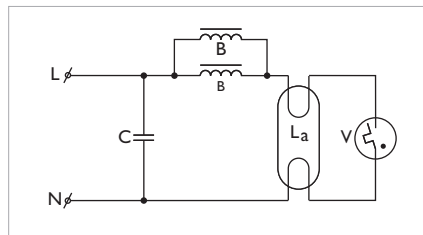

Circuit 5

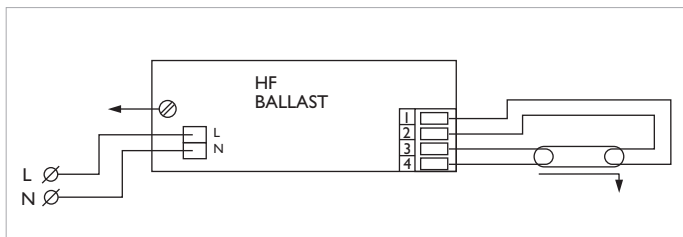

Circuit 6

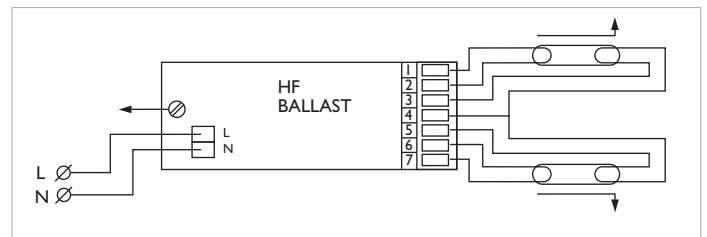

Circuit 7

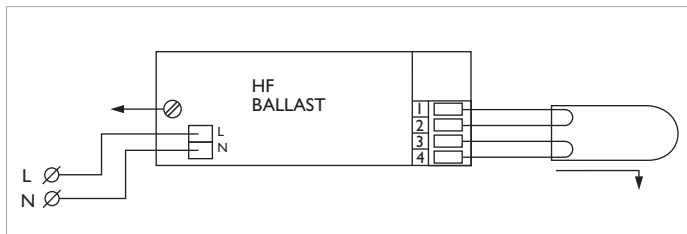

Circuit 8

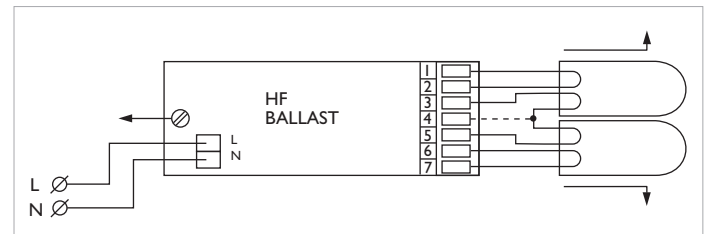

Circuit 9

**For more information or support:**

Philips Lighting B.V.

Zwaanhoefstraat 2

4702 LC Roosendaal

The Netherlands

Tel: +31 165 577906

Fax: +31 165 577907

Email: [uvpurification@philips.com](mailto:uvpurification@philips.com)

[www.philips.com/uvpurification](http://www.philips.com/uvpurification)

Advance Transformers Co.

Web: [www.philips.com/uvpurification](http://www.philips.com/uvpurification)



© Koninklijke Philips Electronics N.V. 2008

All rights reserved. Reproduction in whole or in part is prohibited without prior written consent of the copyright owner. The information presented in this document does not form part of any quotation or contract, is believed to be accurate and reliable and may be changed without notice. No liability will be accepted by the publisher for any consequence of its use. Publication thereof does not convey nor imply any license under patent - or other industrial or intellectual property rights.

3222 635 61811 Data subject to change 09/08